



GALIUS: an ultrafast imaging spectrograph for the study of lightning

MARÍA PASSAS-VARO,^{1,*}  JUSTO SÁNCHEZ,¹ THI NY KIEU,¹ ERNESTO SÁNCHEZ-BLANCO,² AND FRANCISCO J. GORDILLO-VÁZQUEZ^{1,3}

¹Instituto de Astrofísica de Andalucía (IAA), CSIC, PO Box 3004, 18080 Granada, Spain

²Optical Development, Consultant, Avenida Pablo Iglesias 7 Local 5, 41008 Sevilla, Spain

³e-mail: vazquez@iaa.es

*Corresponding author: passasv@iaa.es

Received 18 June 2019; revised 11 September 2019; accepted 16 September 2019; posted 16 September 2019 (Doc. ID 370363); published 8 October 2019

We present the main parameters, design features, and optical characterization of the GrAnada Lightning Ultrafast Spectrograph (GALIUS): a portable, ground-based spectrographic system intended for analysis of the spectroscopic signature of lightning. It has been designed to measure the spectra of the light emitted from natural and triggered lightning and artificial electrostatic discharges at recording speeds up to 2.1 Mfps. It includes a set of four interchangeable gratings covering different spectral ranges (from 375 nm to 854.5 nm) with spectral resolutions from 0.29 nm to 0.76 nm. A set of 10 collector lenses allows the recording of the spectrum of electrostatic discharges and lightning in different scenarios. © 2019 Optical Society of America

<https://doi.org/10.1364/AO.58.008002>

1. INTRODUCTION

Lightning spectroscopy has been a matter of interest to the atmospheric research community since the mid-nineteenth century. Especially nowadays, when the progress of technology makes possible the improvement of both temporal and spatial resolution (XR) of the measurement of lightning spectra due to the incipient development of CCD and CMOS ultra-high-speed cameras and volume phase holographic (VPH) diffraction gratings.

The fastest spectrograph to date designed to record lightning spectra was developed by the Department of Atmospheric Science at the University of Alabama in Huntsville, with a maximum recording speed of 1 Mfps [1,2]. They recorded the first high-speed slit-less spectra of triggered lightning at 660,000 fps, distinguishing its different phases and identifying neutral, singly, and doubly ionized nitrogen, oxygen, and some neutral argon lines, with a lack of any traces of molecular emissions [1].

Higher-speed measurements would give an idea of the initial temporal stages of, for instance, lightning leaders or how high the temperature can become in lightning return-stroke channels. In this sense, we have designed, developed, and calibrated the GrAnada Lightning Ultrafast Spectrograph (GALIUS), the first portable ultrahigh-speed spectrograph designed to analyze key properties such as electron density and gas temperature of lightning and high voltage (HV) electrostatic discharges up to 2.1 Mfps.

2. GALIUS

A. Experimental Device

Figure 1 shows the optical scheme of GALIUS. A total of 22 configurations can be set up, combining 10 interchangeable collector lenses (see Table 1) with two different collimators (see Table 2) and four interchangeable gratings (see Table 3), depending on the spectral range we want to measure. We use R1 to measure the UV spectral range and R2, R3, and R4 to measure the visible–NIR spectral range. Let us call the UV setup the configuration resulting from combining R1 with collector lenses A, B, C, or D and the UV collimator. And let us call the Visible–NIR setup the possible configuration resulting from combining R2, R3, or R4 with collector lenses E, F, G, H, I, or J and the visible–NIR collimator.

The optical scheme of GALIUS, following the light path, consists of a collector lens (see Table 1), optional slit of 50 $\mu\text{m} \times 3$ mm, collimator (see Table 2), grism (see Table 3), camera lens of 50 mm focal length and F#1.2, and a Photron SA-Z CMOS ultrahigh-speed camera. Optical rails and holders set all the components inside a portable housing (see Fig. 2). In the UV scenario, we place a 345 nm high-pass filter between the collimator and the VPH to avoid second-order spectra between 200 nm and 400 nm in the spectral response of a commercial spectrograph that we used to calculate GALIUS instrument function. GALIUS also includes a photometer that triggers the Photron SA-Z camera when a threshold of photons is detected,

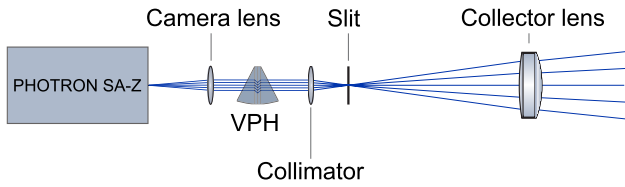

Fig. 1. Optical scheme of the GALIUS CMOS imaging spectrograph.

Table 1. GALIUS Interchangeable Collector Lenses

Lens	Focal Length	F#	Spectral Range
A	25 mm	1	250–425 nm
B	30 mm	1.50	250–425 nm
C	38 mm	1.52	250–425 nm
D	50 mm	1.50	250–425 nm
E	25 mm	1.67	400–1000 nm
F	30 mm	1.50	400–1000 nm
G	40 mm	1.60	400–1000 nm
H	50 mm	1.67	400–1000 nm
I	60 mm	1.50	400–1000 nm
J	200 mm	2.70	400–1000 nm

Table 2. GALIUS Interchangeable Collimators

Spectral Range	Focal Length	F#
UV	105 mm	4.5
Visible–NIR	50 mm	1.2

and a WATEC WAT-902H2 ultimate with a 3005VX4 sensor wide-field camera, to discern the origin of the recorded spectra.

1. Housing

GALIUS is housed in a portable aluminum box of 1100 mm × 380 mm × 230 mm, which can be bent in elevation from 0° to 50° due to a linear actuator and a telescopic mechanism attached on its fixed base (see Fig. 2).

2. Grisms

We have designed four interchangeable grisms. They consist of an embedded VPH transmission grating between two prisms, so that the path of the light remains straight. Table 3 summarizes the specifications of the grisms R1 (UV), R2 (Visible–NIR), R3 (Visible–NIR), and R4 (Visible–NIR).

Table 3. GALIUS Configurations

Grism	Lines/Mm	Spectral Resolution	Spectral Range	Collector Lenses
R1	2086	0.2945 nm	380 nm–450 nm	A, B, C, D
R2	1015	0.7530 nm	464 nm–794 nm	E, F, G, H, I, J
R3	1855	0.3831 nm	587.7 nm–737.8 nm	E, F, G, H, I, J
R4	1727	0.3456 nm	706.7 nm–854.5 nm	E, F, G, H, I, J

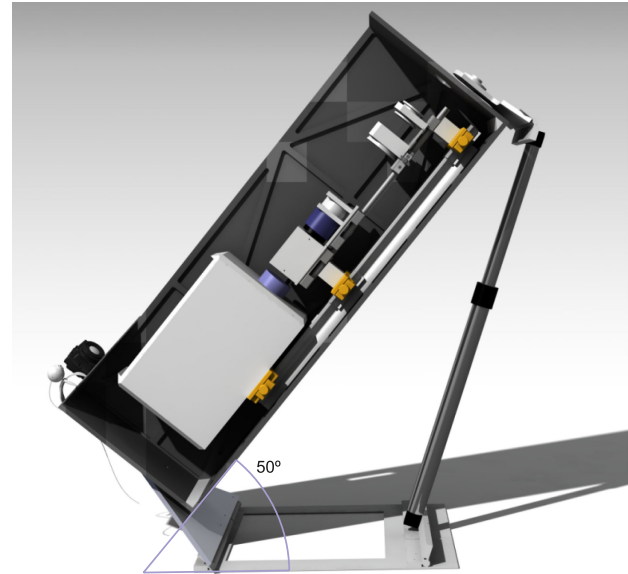
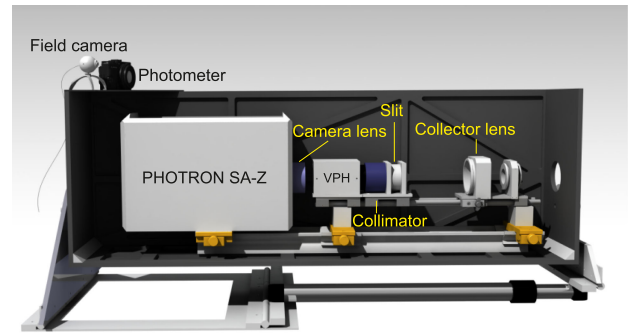

Fig. 2. GALIUS housing.

3. Sensor

The ultrahigh-speed Photron FASTCAM SA-Z includes a highly light-sensitive image sensor (monochrome ISO 50,000) of 1024 × 1024 20 μm square pixels, with 12-bit ADC pixel depth. It provides frame rates up to 2.1 million frames per second (fps) at reduced image resolution. Table 4 summarizes the maximum resolution of the Photron FASTCAM SA-Z sensor, depending on the frame rate.

4. Photometer and Triggering System

The photometer is based on a fast photodiode working under photoconductive mode. It amplifies the optical signal and launches a transistor-transistor logic (TTL) synchronism pulse that triggers the Photron SA-Z camera whenever a threshold in

Table 4. Photron Fastcam SA-Z

Frame Rate	Sensor Size (H × V)
20,000 fps	1024 × 1024
40,000 fps	1024 × 512
700,000 fps	256 × 56
1,000,000 fps	256 × 24
2,100,000 fps	128 × 8

a number of photons is reached. The photometer can launch either a positive or negative TTL pulse with a typical delay of 20 ns. The photometer is very useful to synchronize the Photron SA-Z recording with the initial stage of a spark or lightning and to avoid collapsing the internal buffer of the camera with empty images.

B. Spectrograph Calibration

In order to calibrate GALIUS, we followed the steps previously described for calibrating the GRANada Sprite Spectrograph and Polarimeter (GRASSP) [3] presently in operation for high-spectral-resolution TLE spectroscopy [4–7]. The detailed steps followed to calibrate GALIUS are: (1) distortion correction, to straighten the curved raw spectrum; (2) wavelength calibration, to assign an absolute wavelength to each pixel of the CMOS; and (3) flux calibration, to provide the spectral sensitivity of the spectrograph. Distortion correction and wavelength calibration are done whenever a spectrum is recorded; the 22 different instrument functions (one per each configuration of GALIUS) are calculated once a year.

1. Distortion Correction and Wavelength Calibration

We have implemented software in Python to correct the curvature of the spectrum due to the aberration introduced by the optical elements of GALIUS. We recorded the spectrum of deuterium (for the UV setup) and neon and argon (for the Visible–NIR setup) spectral lamps. Then, we trimmed them so all spectral lines appeared in every row of the spectrum. Then, we identified the corresponding wavelengths by comparing the distances between the spectral lines to the gaps that deuterium, neon, and argon spectra show. We measured the deuterium spectrum with a commercial Jobin Yvon Horiba FHR1000 spectrograph, and we obtained the Ne and Ar spectral lines from [8]. Finally, to straighten the spectrum, we assigned the central pixel of each spectral line to a single wavelength for every row of the spectral image. This software generates a calibration matrix that will be used to correct the distorted spectra recorded with GALIUS, associating every pixel coordinate of the CMOS to an absolute wavelength. This calibration matrix is calculated every time we perform a new set of measurements.

2. Flux Calibration

We measured the spectral response of the 22 different GALIUS setups.

For the UV setup, we measured with GALIUS the spectral radiance of a deuterium lamp (see Fig. 3) directly from the bulb

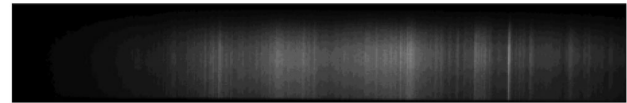

Fig. 3. Spectral image of a deuterium lamp recorded with GALIUS for grism R1 using the collector lens D (50 mm focal length).

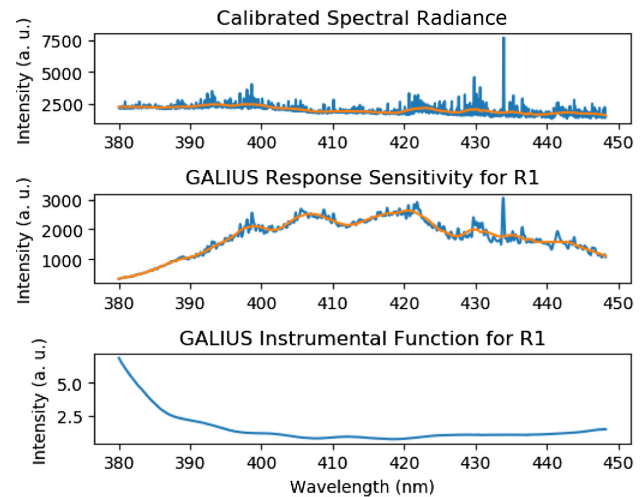

Fig. 4. Spectral sensitivity of GALIUS for grism R1 using the collector lens D (50 mm focal length) for CMOS row number 16.

at 50 fps located at 24.5 cm from the collector lens, measuring in three different regions of the beam, and combining these measurements by terms of the median value of images. We repeated the setup and measured the spectral radiance of the same deuterium lamp with a calibrated Jobin Yvon HORIBA FHR1000 spectrometer. In this case, we located the optic fiber over nine different regions of the deuterium beam with a micrometric regulation screw, and we combined these measurements as their median value. Then we proceeded as in [9]. It is worth highlighting that we could not use an integrating sphere, since the radiance from the lamp was very weak for the UV spectral range, and the system sensitivity was also very low at these wavelengths. From these calculations, we obtained four different instrumental functions.

For the Visible–NIR setups, we repeated the steps defined in [3]. We recorded the spectral radiance of a halogen tungsten spectral lamp (QTH) at 50 fps located at 60 cm from the collector lens, and repeated these measurements with the calibrated Jobin Yvon HORIBA FHR1000 spectrometer using the same calibration setup. From these calculations, we obtained 18 different instrumental functions.

Equation (1) provides the instrument function of GALIUS for row i of the CMOS, according to the steps defined in [9]:

$$IF(\lambda, i) = \frac{S_{FHR1000}(\lambda)}{S_{GALIUS}(\lambda, i)}. \quad (1)$$

As the spectral resolutions of the FHR1000 and GALIUS are different, we could not divide them directly to calculate the spectral sensitivity. To correct this issue, we convolved both responses with a Gaussian curve so that the resulting signals had the same spectral resolution. Figure 4 shows the spectral

sensitivity of row number 16 for grating R1 with a collector lens of 200 mm focal length.

C. Spectral Resolution

We have estimated the spectral resolution of GALIUS by measuring the full width at half-maximum (FWHM) of different spectral emission lines for each VPH. We also estimated the mean resolving power of the spectrograph as $R = \lambda/\delta\lambda$, with $\delta\lambda$ as the FWHM of a certain spectral emission line. The spectral dispersion (D) and FWHM and R mean values are shown in Table 5. The current resolution element is contained in 2.17 to 2.6 pixels average (it changes across field, due to anamorphics and aberrations), which is very close to the Nyquist limit (2 to 2.4 pixels).

D. Spatial Dispersion

We measured the spatial dispersion (XD) of the GALIUS spectrograph for settings F, G, H, and J by measuring the spectrum of the Sun reflected on a full Moon, which subtends about 32 ± 3 min of arc from Earth. The number of pixels of this spectrum on the CMOS varies in the spatial dimension depending on the collector lens, the ratio between this number of pixels and the collector lens focal length being linear. We were unable to measure the spectrum the Sun reflected on the Moon with the UV setup due to the weakness of the spectrum at these wavelengths, so we estimated the XD assuming linearity.

According to Nyquist criterion, the XR is three times the XD. Table 6 shows the XD (second column) and XR (third column) for each collector lens (first column).

E. Stability

We have checked the stability of GALIUS in our laboratory for every VPH by recording the spectrum of the calibration lamps within a time interval of 7 h, and we did not detect any drift in the wavelength. However, we will calibrate in wavelength at the beginning and at the end of a working session to check the stability of the system due to movements during the observation night.

F. Spectrograph Reliability

In Fig. 5, we compare two sparks spectra. The blue one is the calibrated spectrum of the light emitted by a 5 cm spark generated with a Whimshurst machine. It was recorded in our laboratory at 84 kfps and 10 μ s exposure time with GALIUS setting of grism R1 combined with lens D. The orange graph corresponds to the calibrated spectrum of the light emitted by a spark produced by a Van der Graaff generator. It was recorded at

Table 5. GALIUS Spectral Parameters

VPH	D (nm/px)	FWHM (nm)	R
R1	0.1354	0.2945	1409.17
R2	0.3306	0.7530	835.36
R3	0.1483	0.3831	1729.97
R4	0.1481	0.3456	2258.68

Table 6. GALIUS Spatial Parameters

Lens	XD (arc sec/px)	XR (arc min)
A	279.91 ± 26.24	14.00 ± 1.31
B	236.84 ± 22.205	11.84 ± 1.11
C	190.06 ± 17.82	9.50 ± 0.89
D	146.62 ± 13.75	7.33 ± 0.69
E	133.29 ± 12.50	6.66 ± 0.62
F	112.78 ± 10.57	5.64 ± 0.53
G	86.25 ± 8.09	4.31 ± 0.4
H	69.82 ± 6.55	3.49 ± 0.33
I	58.65 ± 5.50	2.93 ± 0.27
J	18.10 ± 1.70	0.91 ± 0.08

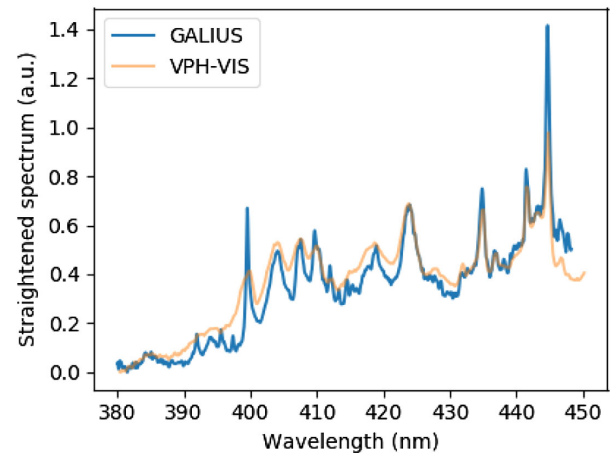

Fig. 5. Spectrum of a spark produced by a Whimshurst machine measured with GALIUS (blue). Spectrum of a spark produced by a small Van der Graaf generator measured with a VPH-VIS spectrograph (orange) [10].

100 kfps and approximately 10 μ s exposure time with a VPH-VIS spectrograph with 0.75 nm spectral resolution and a grating of 1257 lines/mm [10].

Since we are comparing the spectra of two different electrostatic discharges recorded with two different spectrographs at two different spectral and temporal resolutions, these spectra are, hence, different. Nevertheless, both spectra are coincident in peaks, and their background level seems to follow the same slope, so this comparison confirms the reliability of the wavelength and flux calibration of GALIUS between 380 nm and 450 nm.

We have confirmed the same reliability for grisms R2, R3, and R4.

3. CONCLUSION

In this paper we have described the design and development as well as the complete optical characterization of GALIUS, a portable, ground-based, ultrafast spectrographic system for the analysis of the spectroscopic signature of lightning and artificial electrostatic discharges at recording speeds up to 2.1 Mfps with spectral resolutions varying from 0.29 nm to 0.76 nm. GALIUS would allow us to remotely estimate physical parameters of the

lightning channel, such as electron density or gas temperature, among others. It is worth highlighting that GALIUS is currently the fastest spectrograph intended to analyze lightning spectra, improving the temporal resolution of former lightning slit spectrographs by more than three times [1,2,10].

Funding. Ministerio de Economía y Competitividad (ESP2017-86263-C4-4-R); Agencia Estatal de Investigación (SEV-2017-0709); H2020 Marie Skłodowska-Curie Actions (722337).

Acknowledgment. T. N. K. acknowledges a PhD contract through the project SAINT. Authors gratefully acknowledge Dr. Isabel Tanarro for her invaluable assistance in measuring the calibrated lamps spectra with a Jobin Yvon Horiba FHR1000 spectrometer under her supervision in the Instituto de Estructura de la Materia (IEM), CSIC, Madrid, Spain. This work was supported by the Spanish Ministry of Science and Innovation, MINECO, and the FEDER program. Additionally, this work has received funding from the European Union Horizon 2020 research and innovation programme under the Marie Skłodowska-Curie grant agreement SAINT. Authors M. P. V., J. S., T. N. K., and F. J. G. V. acknowledge financial support from the State Agency for Research of the Spanish MCIU through the “Center of Excellence Severo Ochoa” award for the Instituto de Astrofísica de Andalucía.

Disclosures. The authors declare that there are no conflicts of interest related to this paper.

REFERENCES

1. T. D. Walker and H. J. Christian, “Triggered lightning spectroscopy: Part I qualitative analysis,” *J. Geophys. Res. Atmos.* **122**, 8000–8011 (2017).
2. T. D. Walker and H. J. Christian, “Triggered lightning spectroscopy: Part II quantitative analysis,” *J. Geophys. Res. Atmos.* **124**, 3930–3942 (2019).
3. M. Passas, J. Sánchez, E. Sánchez-Blanco, A. Luque, and F. J. Gordillo-Vázquez, “GRASSP: a spectrograph for the study of transient luminous events,” *Appl. Opt.* **55**, 6436–6442 (2016).
4. F. C. Parra-Rojas, M. Passas, E. Carrasco, A. Luque, I. Tanarro, M. Simek, and F. J. Gordillo-Vázquez, “Spectroscopic diagnostics of laboratory air plasmas as a benchmark for spectral rotational (gas) temperature determination in TLEs,” *J. Geophys. Res. (Space Phys.)* **118**, 4649–4661 (2013).
5. M. Passas, J. Sánchez, A. Luque, and F. J. Gordillo-Vázquez, “Transient upper atmospheric plasmas: sprites and halos,” *IEEE Trans. Plasma Sci.* **42**, 2664–2665 (2014).
6. M. Passas, J. M. Madieto, and F. J. Gordillo-Vázquez, “High resolution spectroscopy of an orionid meteor from 700 to 800 nm,” *Icarus* **266**, 134–141 (2016).
7. F. J. Gordillo-Vázquez, M. Passas, A. Luque, J. Sánchez, O. van der Velde, and J. Montanyá, “High spectral resolution spectroscopy of sprites: a natural probe of the mesosphere,” *J. Geophys. Res. Atmos.* **123**, 2336–2346 (2018).
8. A. Kramida, Yu. Ralchenko, and J. Reader, and NIST ASD Team, “NIST atomic spectra database (ver. 5.2),” 2015, <http://physics.nist.gov/asd>.
9. U. Fantz, “Basics of plasma spectroscopy,” *Plasma Sources Sci. Technol.* **15**, S137–S147 (2006).
10. T. D. Walker, “A 21st century investigation of the lightning spectrum,” Ph.D. Thesis dissertation (University of Alabama in Huntsville, 2015).